

## EC DECLARATION OF CONFORMITY FOR MACHINES (DIRECTIVE 98/37/EC)

**Manufacturer:** FAAC S.p.A.

**Address:** Via Benini, 1 - 40069 Zola Predosa BOLOGNA - ITALY

**Declares that:** DOMOGLIDE-B mod. operator

- is built to be integrated into a machine or to be assembled with other machinery to create a machine under the provisions of Directive 98/37/EC;
- conforms to the essential safety requirements of the following EEC directives:  
  
73/23/EEC and subsequent amendment 93/68/EEC.  
89/336/EEC and subsequent amendment 92/31/EEC and 93/68/EEC

and also declares that it is prohibited to put into service the machinery until the machine in which it will be integrated or of which it will become a component has been identified and declared as conforming to the conditions of Directive 98/37/EC.

Bologna, 01 January 2004

The Managing Director  
A. Bassi



## WARNINGS FOR THE INSTALLER GENERAL SAFETY OBLIGATIONS

- 1) **ATTENTION! To ensure the safety of people, it is important that you read all the following instructions. Incorrect installation or incorrect use of the product could cause serious harm to people.**
- 2) Carefully read the instructions before beginning to install the product.
- 3) Do not leave packing materials (plastic, polystyrene, etc.) within reach of children as such materials are potential sources of danger.
- 4) Store these instructions for future reference.
- 5) This product was designed and built strictly for the use indicated in this documentation. Any other use, not expressly indicated here, could compromise the good condition/operation of the product and/or be a source of danger.
- 6) FAAC declines all liability caused by improper use or use other than that for which the automated system was intended.
- 7) Do not install the equipment in an explosive atmosphere: the presence of inflammable gas or fumes is a serious danger to safety.
- 8) The mechanical parts must conform to the provisions of Standards EN 12604 and EN 12605.  
  
For non-EU countries, to obtain an adequate level of safety, the Standards mentioned above must be observed, in addition to national legal regulations.
- 9) FAAC is not responsible for failure to observe Good Technique in the construction of the closing elements to be motorised, or for any deformation that may occur during use.
- 10) The installation must conform to Standards EN 12453 and EN 12445.  
For non-EU countries, to obtain an adequate level of safety, the Standards mentioned above must be observed, in addition to national legal regulations.
- 11) Before attempting any job on the system, cut out electrical power and disconnect the batteries.
- 12) The mains power supply of the automated system must be fitted with an all-pole switch with contact opening distance of 3mm or greater. Use of a 6A thermal breaker with all-pole circuit break is recommended.
- 13) Make sure that a differential switch with threshold of 0.03 A is fitted upstream of the system.
- 14) Make sure that the earthing system is perfectly constructed, and connect metal parts of the means of the closure to it.
- 15) The automated system is supplied with an intrinsic anti-crushing safety device consisting of a torque control. Nevertheless, its tripping threshold must be checked as specified in the Standards indicated at point 10.
- 16) The safety devices (EN 12978 standard) protect any danger areas against **mechanical movement Risks**, such as crushing, dragging, and shearing.
- 17) Use of at least one indicator-light (e.g. FAACLIGHT 12VDC) is recommended for every system, as well as a warning sign adequately secured to the frame structure, in addition to the devices mentioned at point "16".
- 18) FAAC declines all liability as concerns safety and efficient operation of the automated system, if system components not produced by FAAC are used.
- 19) For maintenance, strictly use original parts by FAAC.
- 20) Do not in any way modify the components of the automated system.
- 21) The installer shall supply all information concerning manual operation of the system in case of an emergency, and shall hand over to the user the warnings handbook supplied with the product.
- 22) Do not allow children or adults to stay near the product while it is operating.
- 23) Keep remote controls or other pulse generators away from children, to prevent the automated system from being activated involuntarily.
- 24) Transit is permitted only when the automated system is idle.
- 25) The user must not attempt any kind of repair or direct action whatever and contact qualified personnel only.
- 26) Do not short-circuit the poles of the batteries and do not try to recharge the batteries with power supply units other than those provided with the equipment.
- 27) Do not throw exhausted batteries into containers for other waste but dispose of them in the appropriate containers to enable them to be recycled. Disposal costs have already been paid for by the manufacturer.
- 28) Maintenance: check at least every 6 months the efficiency of the system, particularly the efficiency of the safety devices (including, where foreseen, the operator thrust force) and of the release devices.
- 29) **Anything not expressly specified in these instructions is not permitted.**

## Notes on DOMOGLIDE-B work batteries

The battery supplied with the DOMOGLIDE-B operator is a **WORK BATTERY** which directly powers the automated system. ***It is not a back-up battery.***

The battery is recharged by the control board to which it is connected via the transformer and a specific integrated circuit. Bear in mind that it takes about 10 to 20 minutes of recharging to recover the energy used during an opening/closing cycle (this value varies according to operating ambient temperature, battery life and type of system).

At installation, the batteries, due to storage, may not be fully charged and thus enable the gate to operate only a few times before discharging completely. That is why, before installing a new system, we recommend to fully charge the supplied batteries, or provide at least two identical fully charged batteries. In this way, you will be able to carry out the system programming operations and run the functional checks.

### HOW TO CHARGE THE BATTERIES FOR THE FIRST TIME

Charging can be done directly at the bench before the system is installed. Follow the instructions referring to the figure below:

- 1) connect the secondary winding of the 12Vac transformer (supplied separately) to connector J2 of the board and the primary winding to mains voltage;  
**Note:** if not using the transformer supplied by FAAC, make sure that the secondary winding is 12Vac - 16VA.
  
- 2) connect the battery to the J4 connector on the board and allow it to charge for about 12 hours.

**NOTE:** While the batteries are being charged, LED P of the board (see Fig. 19 and para. 8.2) may change from fast flashing light (a flash about every 250msec means the battery is discharged) to steady light (battery charged). Even if the LED stays lighted steady a little while after you start charging, leave the batteries connected for the whole of the indicated time.

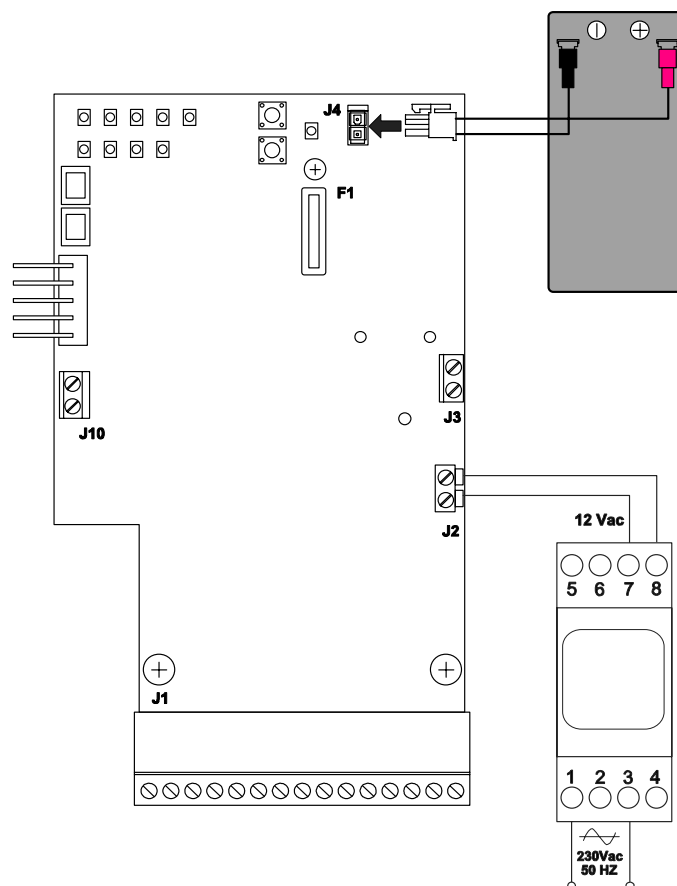

## DOMOGLIDE-B automated system

These instructions apply to the following model:

### FAAC DOMOGLIDE-B

The DOMOGLIDE-B automated system automates residential sliding gates with leaves of up to 5 m in length and 300 kg in weight.

It consists of non-reversing electro-mechanical gearmotor, powered by a 12Vdc work battery coupled to a control board recharging the battery. The board can be programmed and is used to set the following: function logics, work times (by self-learning) and pause times, leaf speed, anti-crushing sensitivity, and partial opening width.

The non-reversing system guarantees the gate will automatically lock when the motor is not operating. A release system enables the gate to be moved by hand in case of malfunction.

**The DOMOGLIDE-B automated system was designed and built for controlling vehicle access. Do not use for any other purpose.**

**Tab. 1** - Technical specifications of DOMOGLIDE-B operator

MODEL	DOMOGLIDE-B
Power supply	12Vdc (by battery)
Rated absorbed power (W)	48
Max linear load-free speed (m/min.)	15
Static force (N)	150
Use frequency (%)	20 (1)
Consecutive cycles on charged battery	~10
Battery recharge time	~10' for each completed cycle
Operating ambient temperature (°C)	-20 ÷ +55
Operator weight (Kg)	5.3
Protection class	IP 44
Leaf max length (m)	5
Leaf max weight (kg)	300
Operator overall dimensions LxHxD (mm)	see Fig.2

(1) Reference value for maintaining full efficiency of batteries. 10 consecutive cycles can be averagely performed with charged battery. The recovery time (battery recharge) is approx. 10' each cycle performed. The consecutive cycles could be reduced by over 50% at low temperatures (< 0°C).

## 1. DESCRIPTION AND TECHNICAL SPECIFICATIONS

## 2. DIMENSIONS

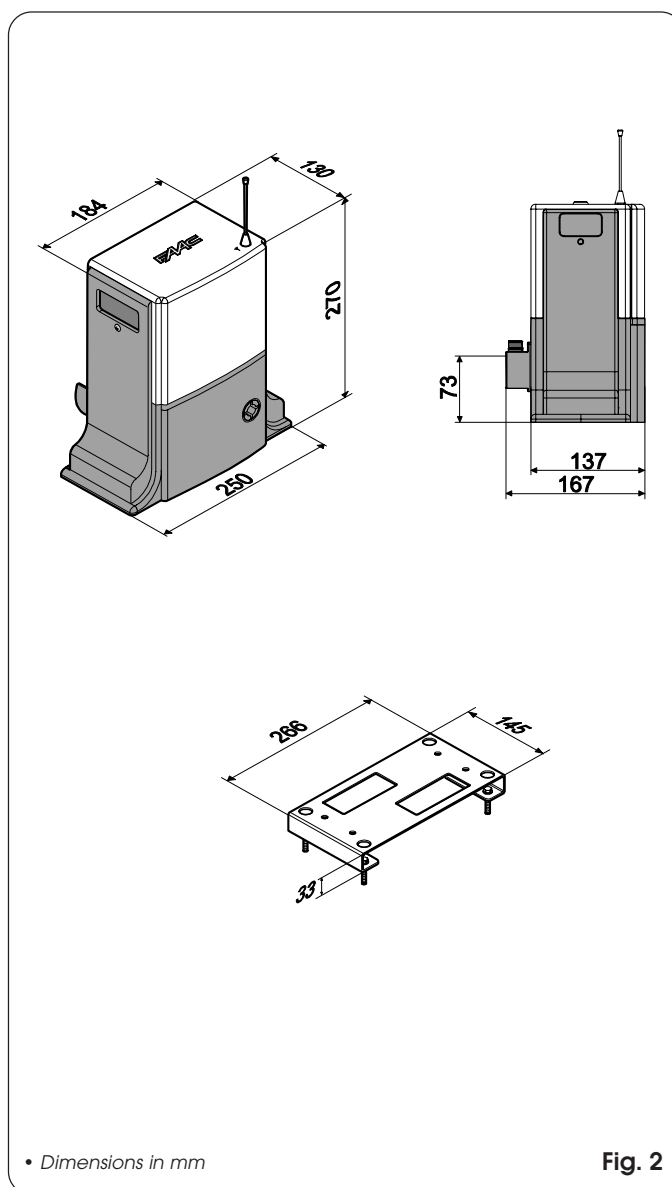
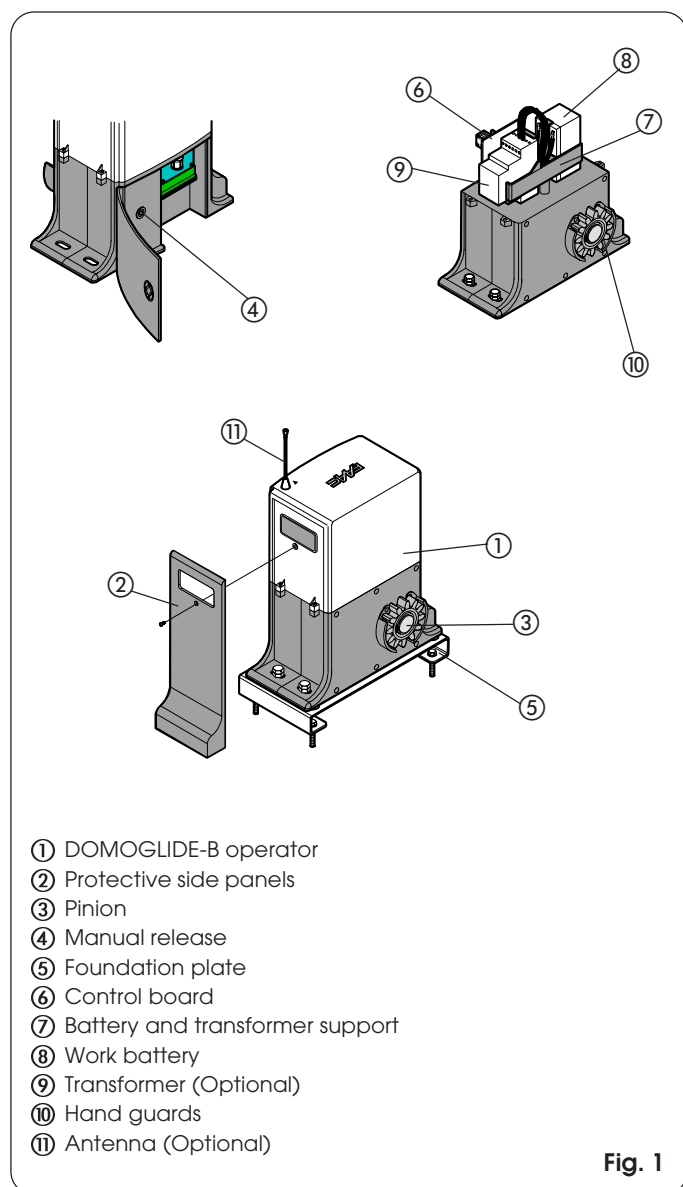

3. DESCRIPTION OF SYSTEM - ELECTRICAL EQUIPMENT (standard system)

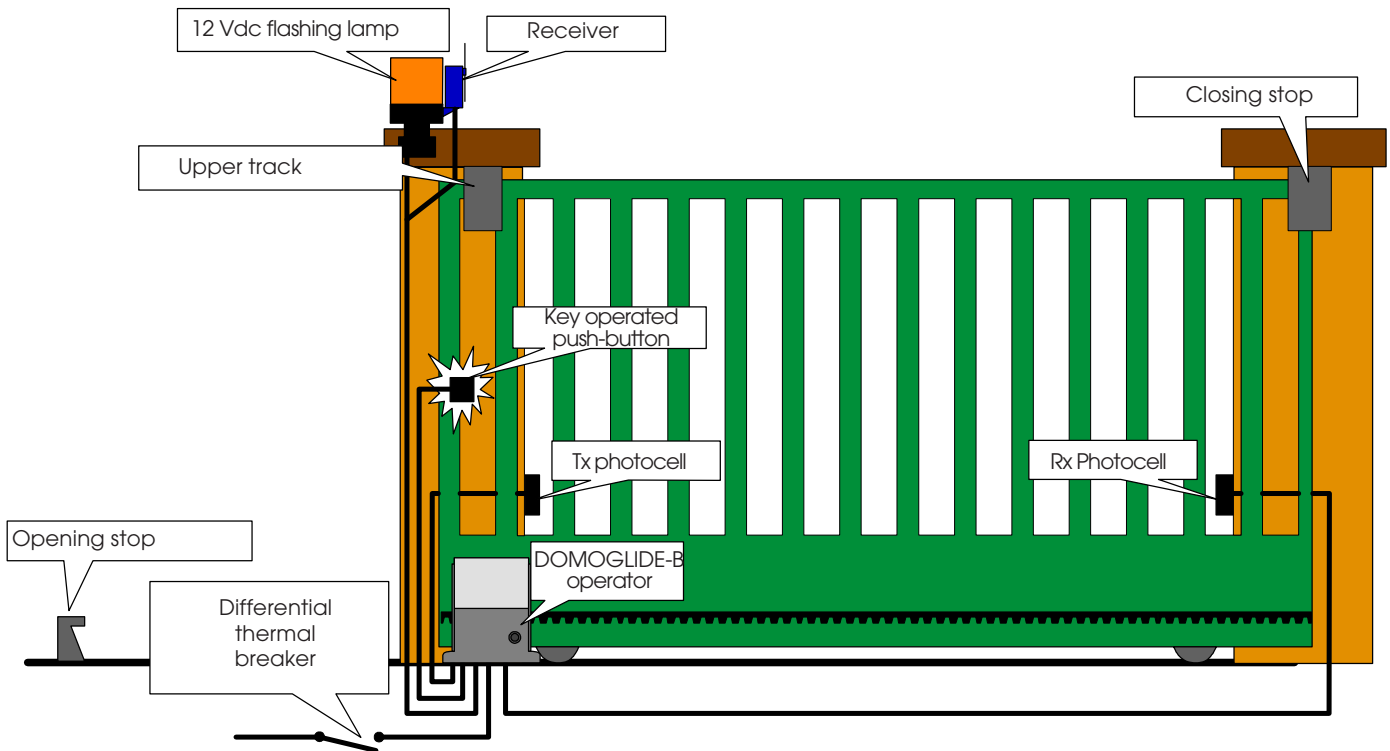

Fig. 3

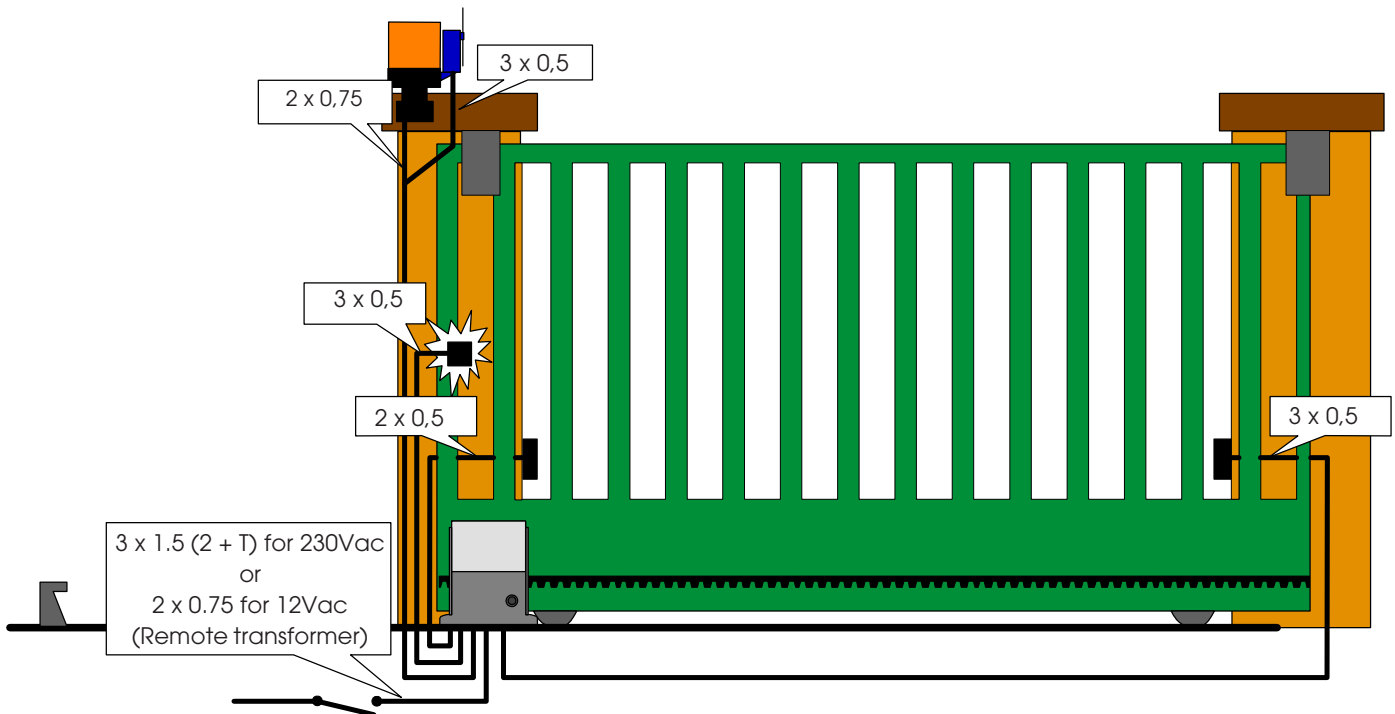

Fig. 4

Notes:

- 1) To lay electric cables, use adequate rigid and/or flexible tubes.
- 2) To avoid any kind of interference **always separate** low voltage connection cables from 230Vac power cables.
- 3) The transformer can be remotely located up to a distance of 100 m from the unit.

## 4. INSTALLING THE AUTOMATED SYSTEM

### 4.1. Preliminary checks

To ensure safety and an efficiently operating automated system, make sure the following conditions are observed:

- The structure of the gate must be suitable for being automated. In particular, check that the structure is sufficiently strong and rigid, and that its dimensions and weight conform to those indicated in the technical specifications.
- Make sure that the gate slides without any inclination.
- Make sure that the gate moves uniformly and correctly, without any irregular friction during its entire travel.
- The soil must permit sufficient stability for the expansion plugs securing the foundation plate.
- Check if the upper guide and travel limit mechanical stops are installed.
- Remove any locks and lock bolts.

We advise you to have any metalwork carried out before the automated system is installed.

### 4.2. repairing the foundation plate

Use the 4 supplied caged nuts, as shown in Fig. 5, in the 4 square holes of the plate.

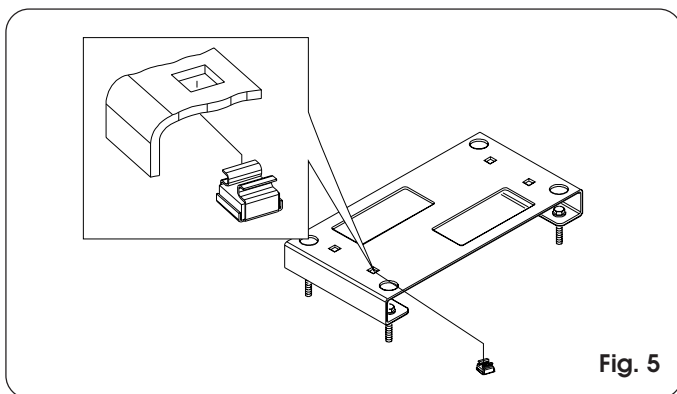

Fig. 5

### 4.3. Securing the foundation plate

- 1) The foundation plate must be located as shown in Fig. 6 (right closing) or Fig. 7 (left closing) to ensure the rack and pinion mesh correctly.
- 2) Secure the foundation plate to the floor, using adequate expansion plugs (Fig. 8) and provide one or more sheaths for routing the electric cables through the plate (Figs. 6-7 Ref. ①). Using a spirit level, check if the plate is perfectly horizontal.

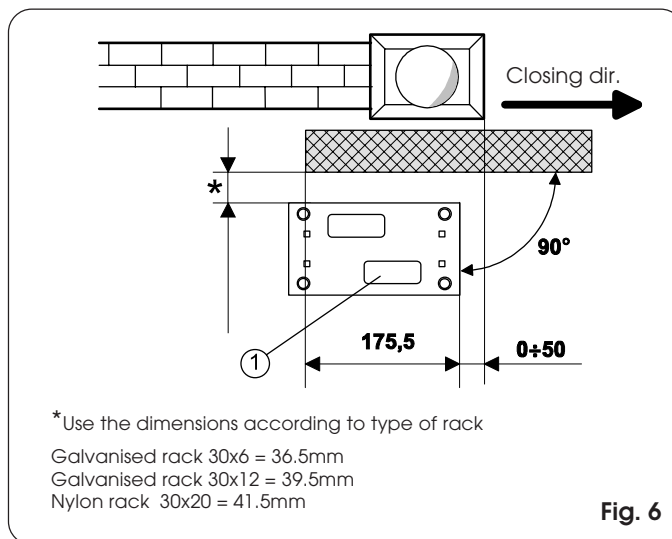

Fig. 6

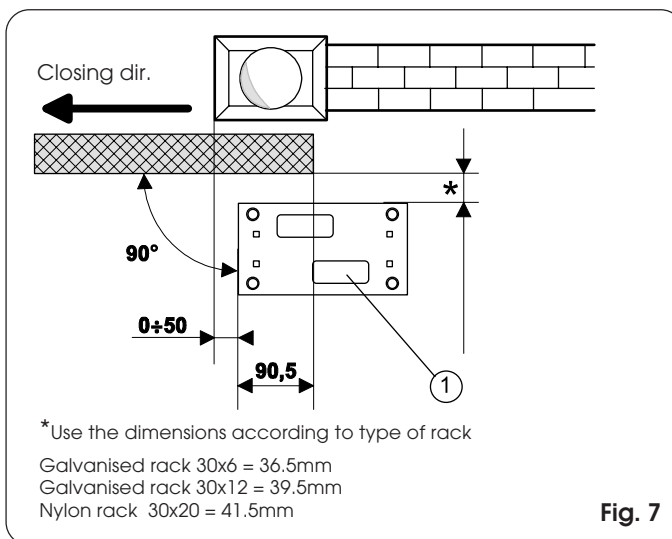

Fig. 7

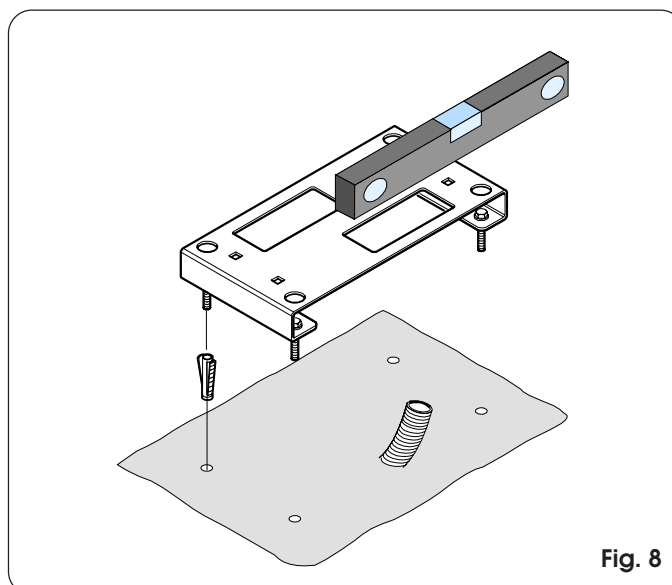

Fig. 8

**4.4. Positioning the operator**

- Lay the electric cables for connection to the accessories and power supply as shown in Fig. 4. To facilitate making the connections, allow the cables to project by the required length for connection to the terminal board, transformer and decoding card (if provided).
- Position the operator on the plate, using the supplied screws as shown in Fig. 9.

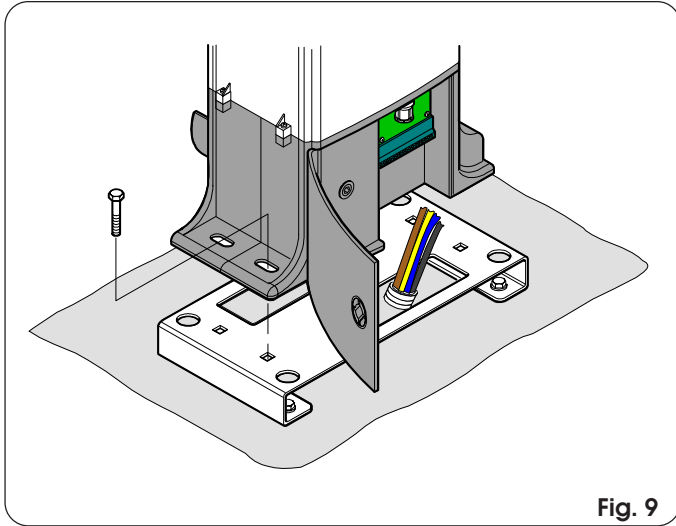

Fig. 9

**4.5. Adjusting the operator**

- Adjust the distance of the operator from the gate by referring to Fig. 10.

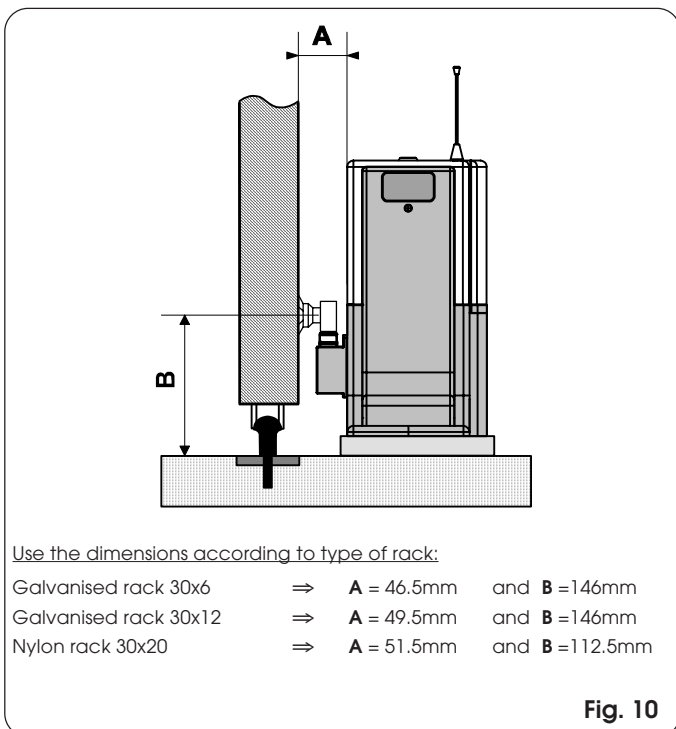

Fig. 10

**4.6. Securing the operator**

- Temporarily fix the operator by slightly tightening the screws as shown in Fig. 11.

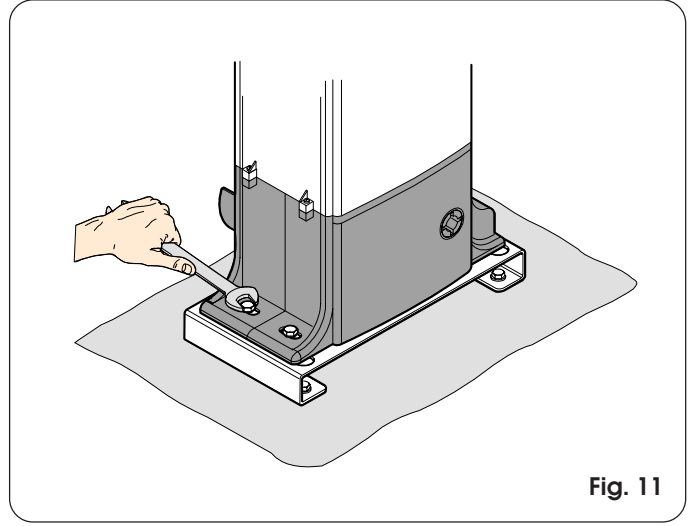

Fig. 11

**4.7. Releasing the operator**

Prepare the operator for manual operating mode as described below:

- Open the protective door with a coin.
- Take the supplied key located inside the door, fit it in the release system and turn it clockwise until it reaches the mechanical stop (Fig. 12).

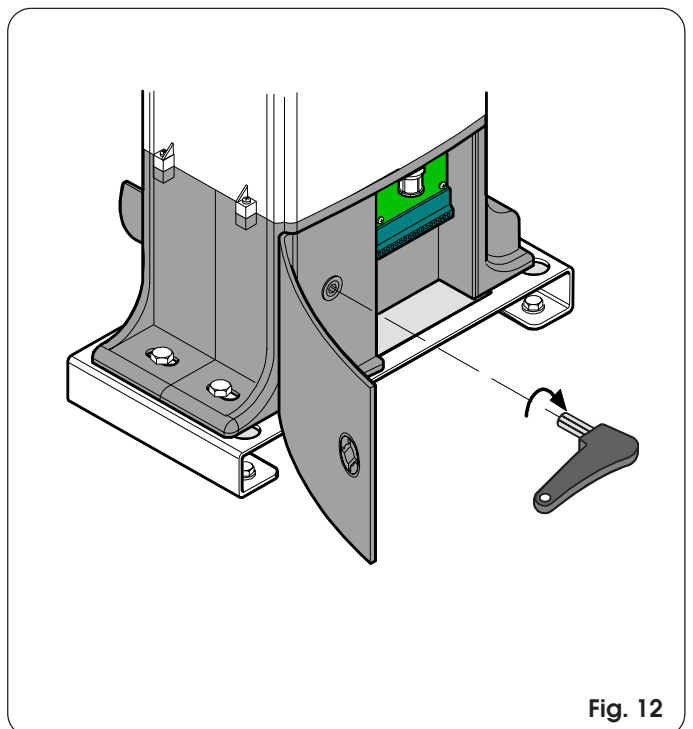

Fig. 12

## 4.8 Installing the rack

### 4.8.1. Steel rack to be welded (Fig. 13)

- 1) Place the three threaded pawls on the rack element, positioning them at the top of the slot. In this way, the slot play will enable any adjustments to be made.
- 2) Manually take the gate into its closing position.
- 3) Lay the first piece of rack at appropriate level on the pinion and weld the threaded pawl on the gate as shown in Fig. 16.
- 4) Move the gate manually, checking if the rack is resting on the pinion, and weld the second and third pawl.
- 5) Bring another rack element near to the previous one, using a piece of rack (as shown in Fig. 17) to synchronise the teeth of the two elements.
- 6) Move the gate manually and weld the three threaded pawls, so proceeding until the gate is fully covered.

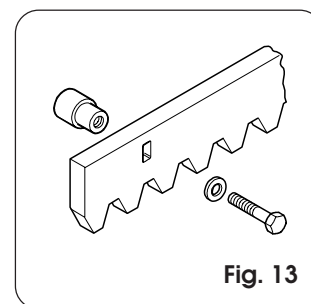

Fig. 13

### 4.8.2. Steel rack to be screwed (Fig. 14)

- 1) Manually take the gate into its closing position.
- 2) Lay the first piece of rack at the appropriate level on the pinion and place the spacer between rack and gate, positioning it at the top of the slot.
- 3) Mark the hole position on the gate. Drill a  $\varnothing 6.5$  mm hole and thread with a  $\varnothing 8$  mm tap. Screw the bolt.
- 4) Move the gate manually, checking if the rack is resting on the pinion, and repeat the operations at point 3.
- 5) Bring another rack element near to the previous one, using a piece of rack (as shown in Fig. 17) to synchronise the teeth of the two elements.
- 6) Move the gate manually and carry out the securing operations as for the first element, proceeding until the gate is fully covered.

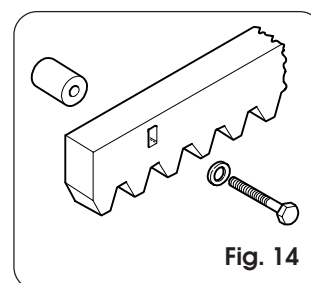

Fig. 14

### 4.8.3. Nylon rack to be screwed (Fig. 15)

- 1) Manually take the gate into its closing position.
- 2) Lay on the pinion the first piece of rack at the appropriate level and mark the hole position on the gate; make a hole with a 4 mm bit and screw the 6x20 mm self-tapping screw with reinforcing plate.
- 3) Move the gate manually, checking if the rack is resting on the pinion, and repeat the operations at point 2.
- 4) Bring another rack element near to the previous one, using a piece of rack (as shown in Fig. 17) to synchronise the teeth of the two elements.
- 5) Move the gate manually and carry out the securing operations as for the first element, proceeding until the gate is fully covered.

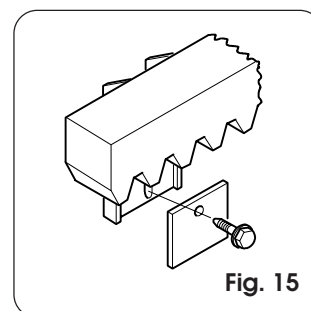

Fig. 15

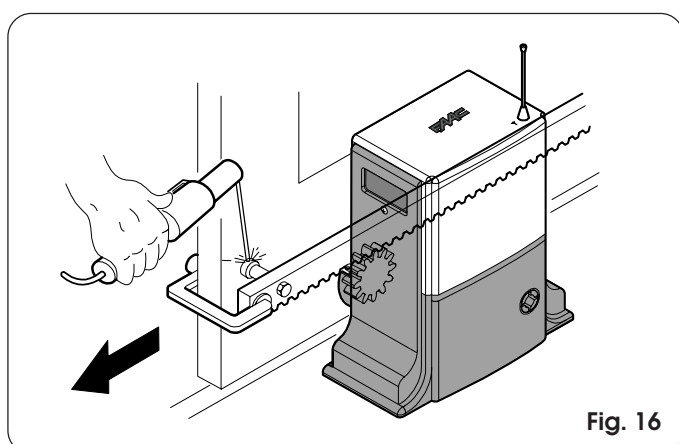

Fig. 16

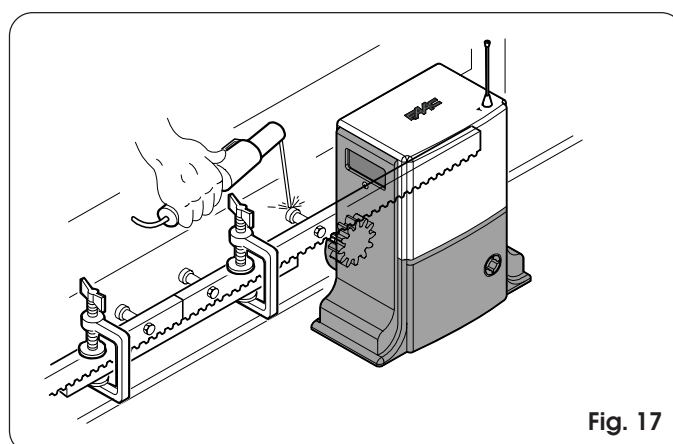
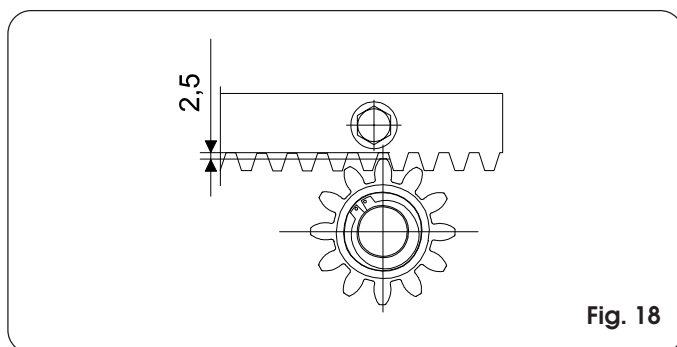

Fig. 17

### Notes on rack installation

- Make sure that, during the gate travel, all the rack elements mesh correctly with the pinion.
- Do not, on any account, weld the rack elements either to the spacers or to each other.
- When you have finished installing the rack, adjust the distance between the pinion teeth and the rack groove, checking if the distance is 2.5 mm (Fig. 18) along the entire travel, using the rack slots.
- Manually check if the gate habitually reaches the travel limit mechanical stops and make sure that there is no friction during gate travel.
- Do not use grease or other lubricants between rack and pinion.



**Fig. 18**



## CONTROL BOARD

### WARNINGS

**Attention:** Before attempting any job on the control board (connections, maintenance), cut out electric power and the battery.

-Install, upstream of the system, a differential thermal breaker with adequate tripping threshold.

-Always separate 230VAC power cable from control and safety cables (push-buttons, receiver, photocells, etc.). To avoid any electric noise, use separate sheaths or a shielded cable (with earthed shield).

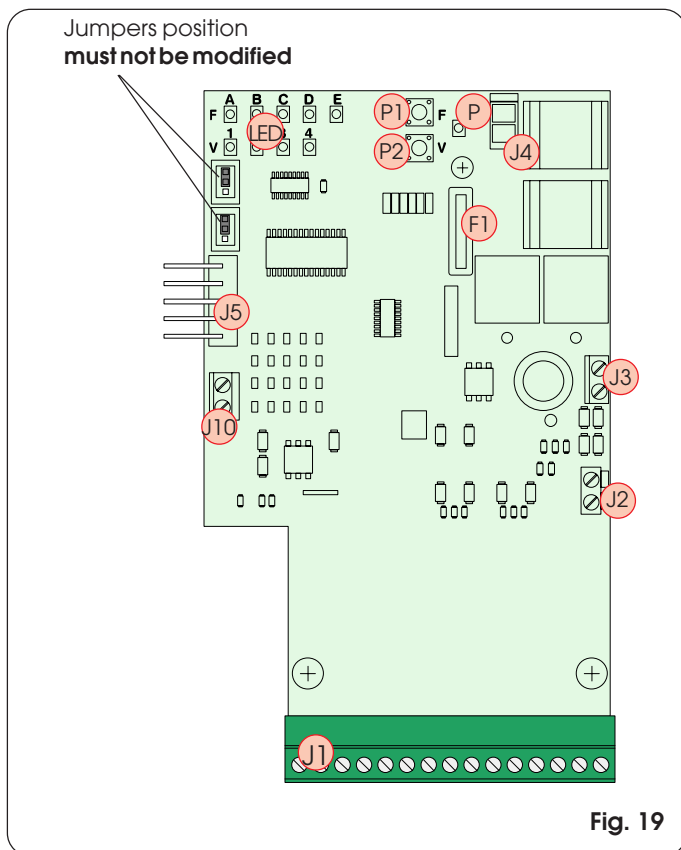

Fig. 19

### 5. BOARD LAYOUT

<b>LED</b>	Programming LEDs
<b>P</b>	Power ON and diagnostics LED
<b>P1</b>	"Function" programming push-button
<b>P2</b>	"Value" programming push-button
<b>F1</b>	Battery and motor fuse F20A
<b>J1</b>	Accessories Terminal board
<b>J2</b>	Transformer Terminal board
<b>J3</b>	Motor connection terminal board
<b>J4</b>	Battery connector
<b>J5</b>	Minidec/RP Receiver connector
<b>J10</b>	Magnetic sensor terminal board

### 6. CONTROL BOARD TECHNICAL SPECIFICATIONS

Tab. 2 - Technical specifications

<b>Power supply</b>	12Vac
<b>Batteries</b>	Hermetic Pb 12Vdc 1.2Ah - dimensions 96x46x50
<b>Transformer characteristics</b>	Primary 230 Vac ~ 50/60Hz - Secondary 12 Vac - 16VA
<b>Motor max current</b>	15A
<b>Operating ambient temperature</b>	-20°C ÷ +55°C
<b>Protection fuses</b>	N° 1 - 20A
<b>Anti-crushing function</b>	Encoder / Current control
<b>Accessories max. load at 24 Vdc</b>	150 mA
<b>Rapid connector max load</b>	50 mA
<b>Function logics</b>	Automatic / "Stepped" automatic / Safety device / Semi-automatic
<b>Opening/closing time</b>	By self-learning
<b>Pause time</b>	Programmable: 5, 10, 20, 30 sec.
<b>Partial opening width</b>	90, 120, 150, 180 cm.
<b>Speed</b>	Selectable on 4 levels
<b>Static force adjustment</b>	Selectable on 4 levels
<b>Deceleration</b>	Electronic
<b>Terminal board inputs</b>	Open - Partially Open - Stop - Safety devices at opng. - Safety devices at clsgng. - Sensor
<b>Terminal board outputs</b>	Motor - Flashing lamp - indicator-light - Accessories 24 Vdc - 12 Vdc power supply
<b>Connectors</b>	Minidec cards - RP cards - Battery
<b>Programmable functions</b>	Logic - pause time - partial opening width - anti-crushing force - operator speed

**7. ELECTRICAL CONNECTIONS**

Wire up as shown in Fig. 20

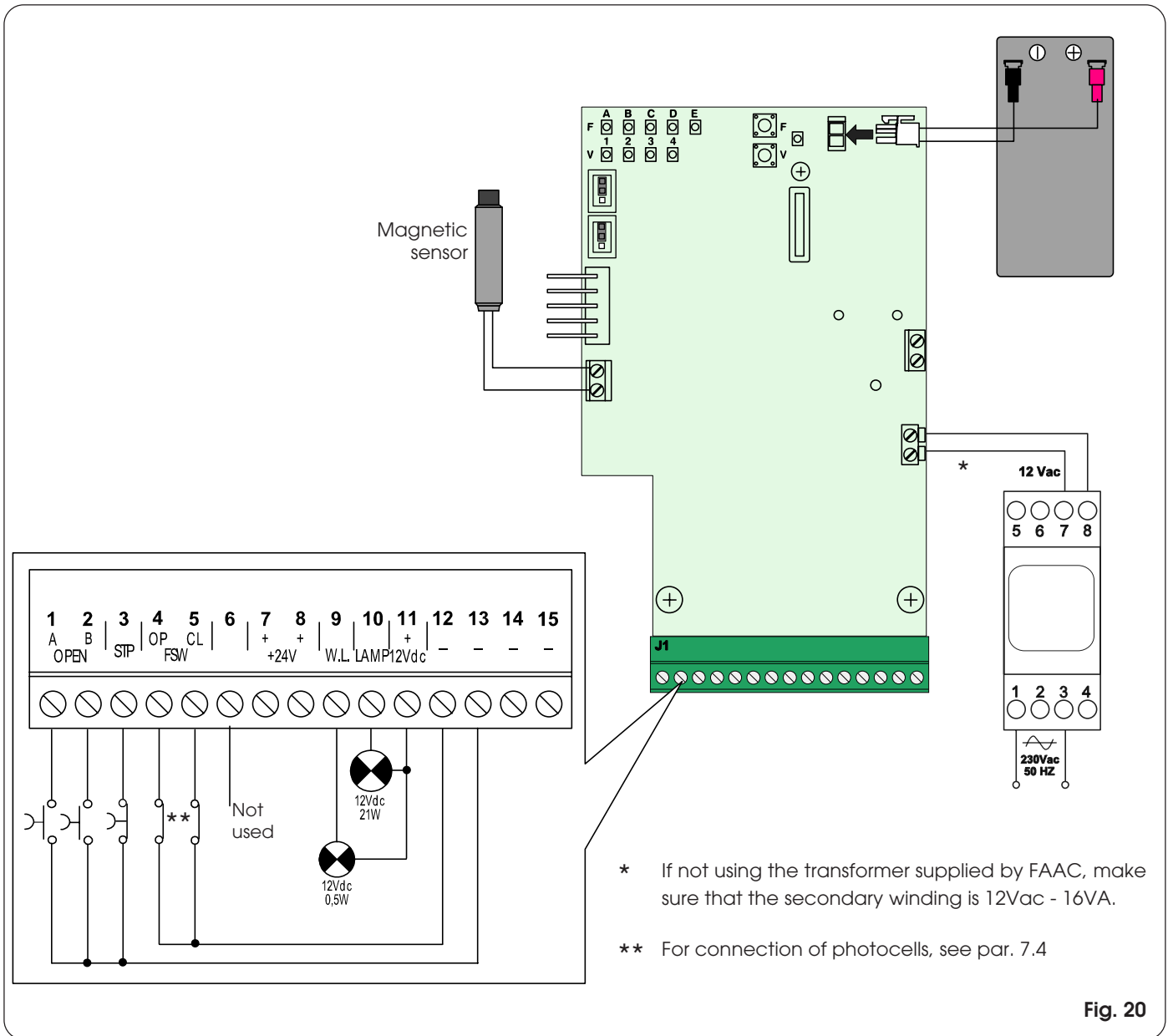

**7.1 Description of J1 terminal board**

**Tab. 3** - Description of accessories connection

Terminal	Description	Connected accessory
1	OPEN A (total opening command)	Device with NA contact (e.g. key operated push-button)
2	OPEN B (partial opening command)	Device with NA contact (e.g. key operated push-button)
3	STOP (gate lock command)	Device with NC contact. <b>(1)</b>
4	FSW OP (opening safety devices contact)	Photocells (e.g. SAFEBEAM) <b>(1)</b>
5	FSW CL (closing safety devices contact)	Photocells (e.g. SAFEBEAM) <b>(1)</b>
6	NOT USED	/
7 - 8	+ (positive for 24V power supply)	Accessories MAX total absorption of 150mA
9 - 11	W.L. (power supply to indicator light)	12V - 0.5W lamp
10 - 11	LAMP (power supply to flashing lamp)	FAACLIGHT 12V flashing lamp
12 ÷ 15	- (negative for 24Vdc power supply)	/

**(1)** If you are not using any accessories, connect the terminal to earth (terminals 12 ÷ 15).

**Note:** when the automated system is idle, the power supply (+24 V) to accessories is disabled.

**7.2 Wiring the motor**

Wire the DOMOGLIDE-B motor according to the gate closing direction as shown in the figure below.

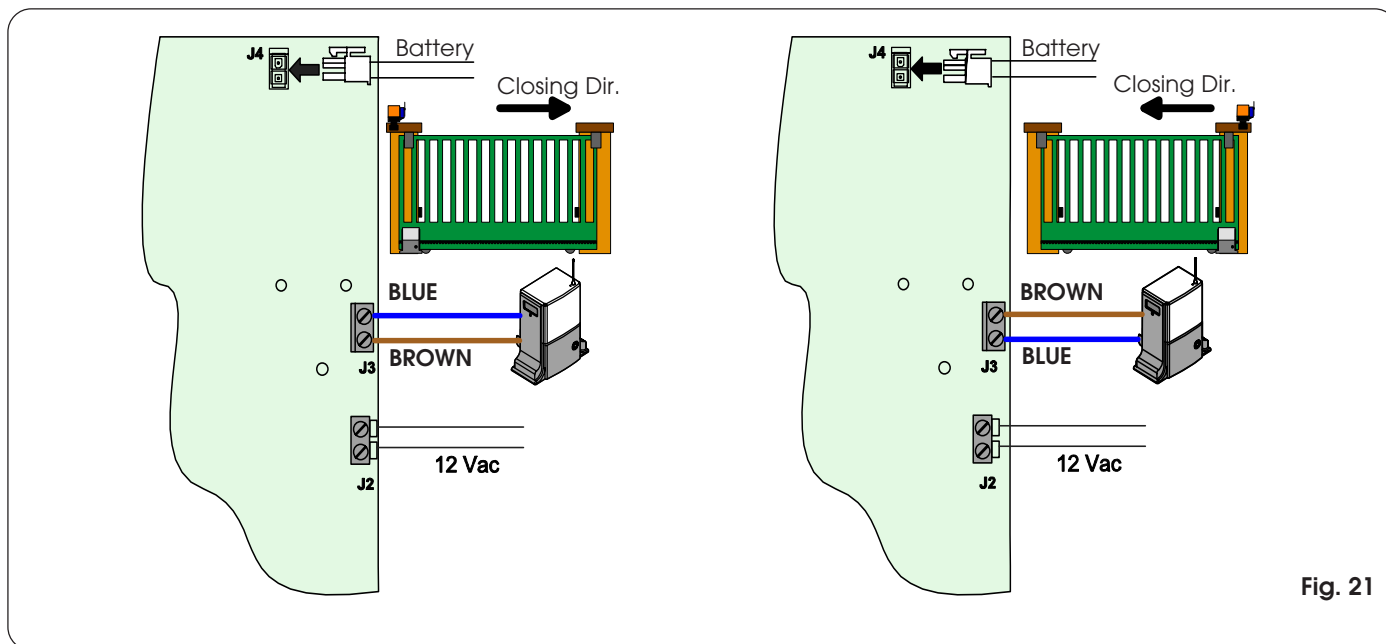

Fig. 21

**7.3 Connection of transformer (optional)**

Fit the transformer support as shown in Fig. 22. Place the transformer in its compartment, as shown in Fig. 23, and make the connection as shown in Fig. 20.

Alternatively, the transformer can be remotely located up to a distance of 100 m from the unit, using a 2 x 0,75mm<sup>2</sup> cable.

If not using the transformer supplied by FAAC, make sure that the secondary winding is 12Vac - 16VA.

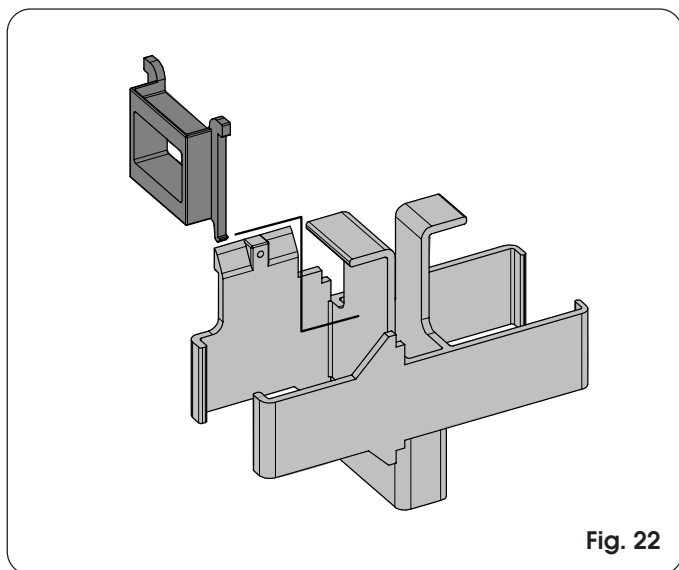

Fig. 22

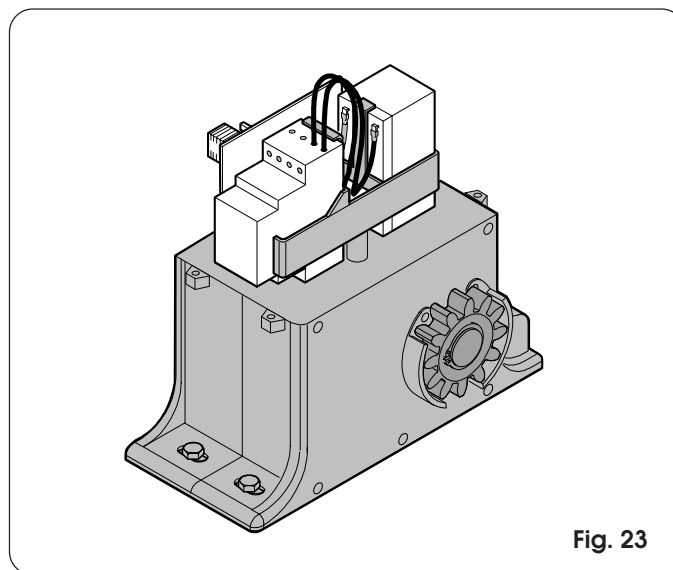

Fig. 23

**7.4 Connection of photocells and safety devices**

Before connecting the photocells (or other devices) we advise you to select the type of operation according to the movement area to be protected (see Fig. 24).

**N.B.:** If two devices with N.C. contact have the same function, they must be connected to each other in series (Fig. 25).

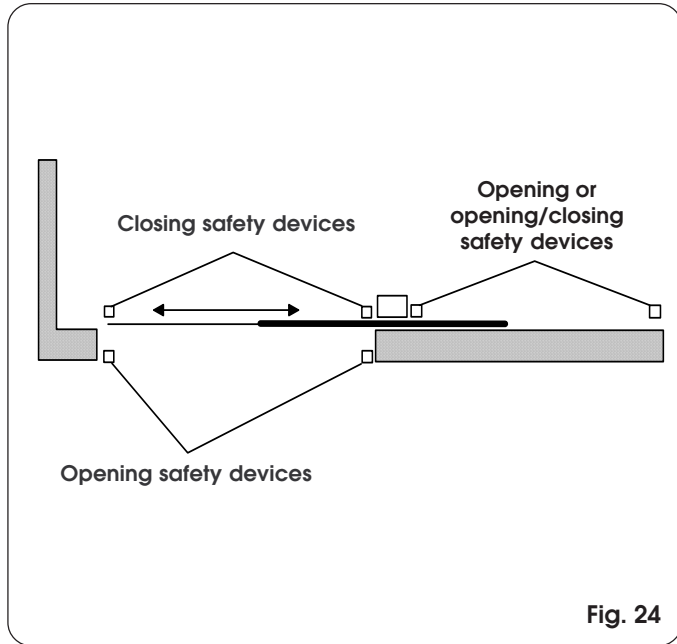

Fig. 24

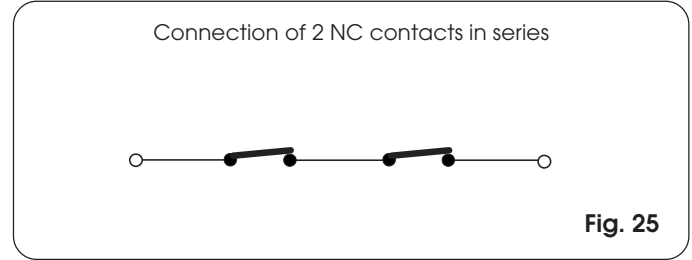

Fig. 25

**N.B.:** If two devices with N.A. contact have the same function, they must be connected to each other in parallel (Fig. 26).

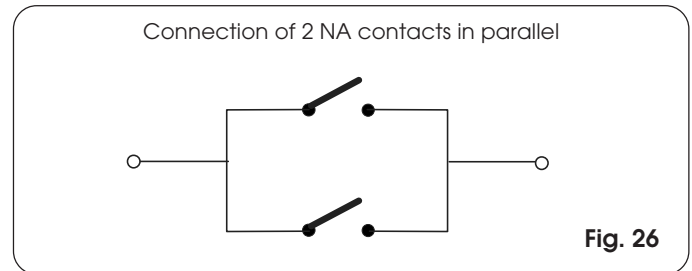

Fig. 26

**Attention:** a maximum of 2 pairs of SAFEBEAM photocells can be connected to the control board

**Examples of photocell connections**

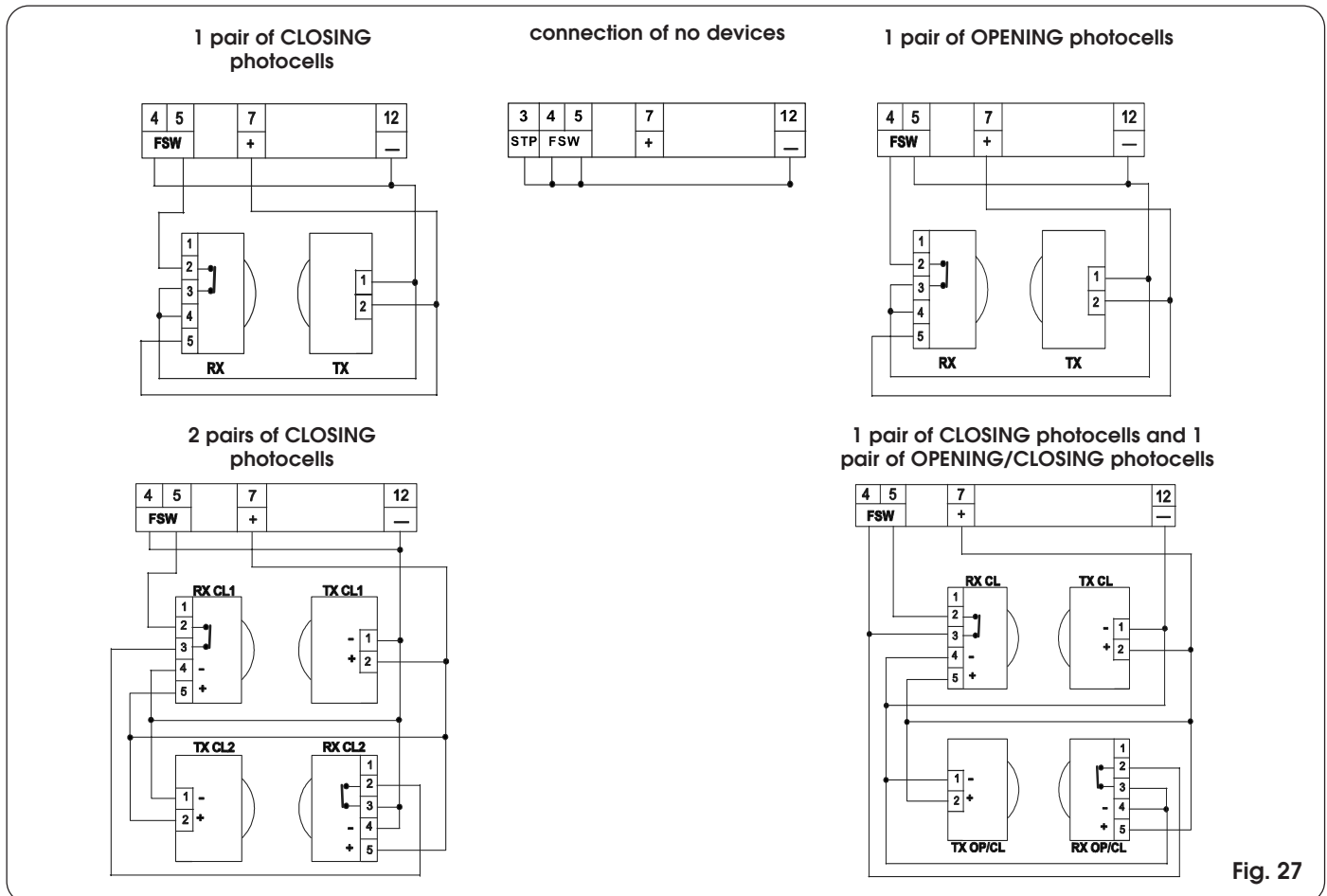
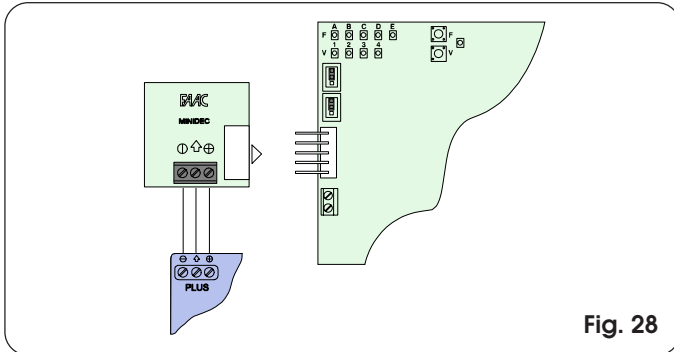

Fig. 27

**7.5 Connection of MINIDEC, RP cards**

Insert the MINIDEC decoding card or RP card in the block connector J5 (Fig. 19) as indicated in Fig. 28 showing the connection of a MINIDEC card.

For programming the decoding cards, consult the individual instructions.



**Fig. 28**

**8. START-UP**

**8.1 Powering up the system**

After making all the cable connections we described previously, power up the system to enable diagnostics, positioning of the travel limit magnets, check of inputs status and programming.

**8.2 Diagnostics**

LED "P" (see Fig.19) - visible from inside the enclosure - performs the diagnostics function. The LED has 4 statuses as shown in the table below:

**Tab. 4 - LED P status description**

Steady light	Mains power present and battery charged.
Slow flashing (lights every second)	Mains power not supplied for not more than 5 minutes, with battery charged. When mains power returns, the LED stays lighted steadily. If mains power is still not supplied, the LED goes off (SLEEP mode).
Rapid flashing (lights every 250 msec)	Mains power present and battery discharged ( <i>gate locked</i> ). The LED continues to flash rapidly until the battery has recharged sufficiently. If mains power is not supplied, the LED goes off (SLEEP mode).
Light OFF	No mains power supplied (SLEEP mode).

**Note:** in the SLEEP mode, an OPEN pulse is sufficient to move the gate (with charged battery)

**8.3 Positioning the travel limit magnets**

**8.3.1 Prearrangement**

The DOMOGLIDE-B operator is supplied with a sensor which, by detecting the transit of two magnets secured to the top of the rack, commands the gate to stop when closing or opening. Procedure for correct positioning of the two supplied magnets:

- Assemble the magnets according to the type of rack used:
  - Galvanised rack 30x6 module 4 (Fig. 29 - Ref. ①)
  - Galvanised rack 30x12 module 4 (Fig. 29 - Ref. ②)
  - Reinforced nylon rack 30x20 module 4 (Fig. 29 - Ref. ③)

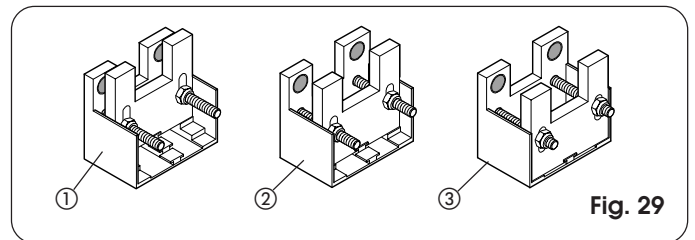

**Fig. 29**

**8.3.2 Positioning**

- Position the magnets on the rack as shown in Fig. 30 Ref ①. Make sure that distance between the magnet and the operator's body is 5mm max (Fig. 30 Ref. ②).
- Fully tighten the operator fixing screws(Fig. 11).

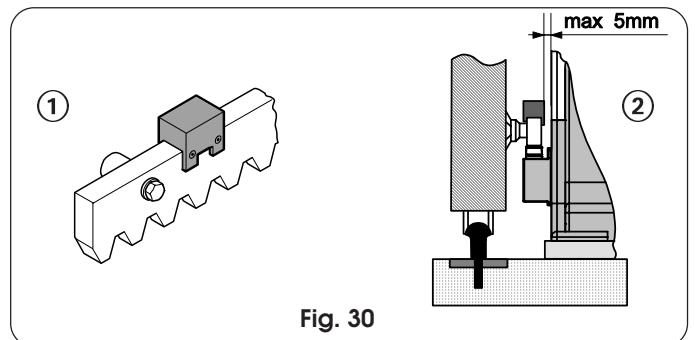

**Fig. 30**

**8.3.3 Adjustment and Fixing**

- Press push-button P2 (Fig. 31 and par. 8.4) to enter the inputs status function.

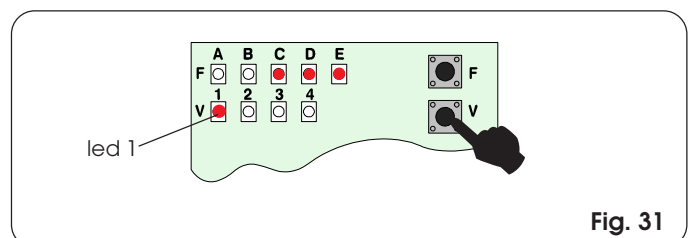

**Fig. 31**

- Manually take the gate to opening position, but allow a space of 2 cm from the travel limit mechanical stop.
- Slide the magnet on the rack (Fig. 32) until you see that LED1 on the control board goes off (Fig. 31).
- Tighten the magnet's securing screws.

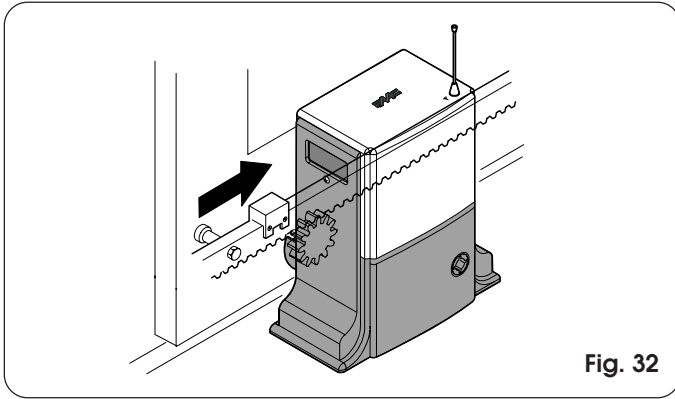

Fig. 32

- Manually take the gate to closing position, but allow a space of 2 cm from the travel limit mechanical stop.
- Slide the magnet on the rack (Fig. 33) until you see that LED1 on the control board goes off (Fig. 31).
- Tighten the magnet's securing screws.

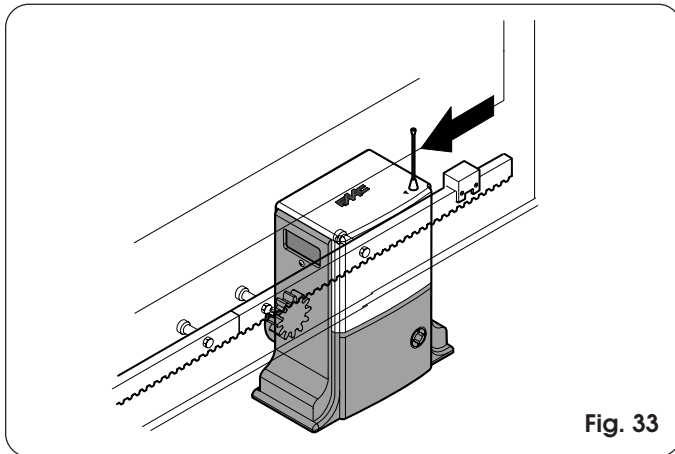

Fig. 33

**8.3.4 Operator locked**

- Make sure the gate is in its closed position.
- Turn the release key anti-clockwise (Fig. 34).
- Remove the release key and put it back in its place; close the protective door.
- Move the gate until the release meshes.

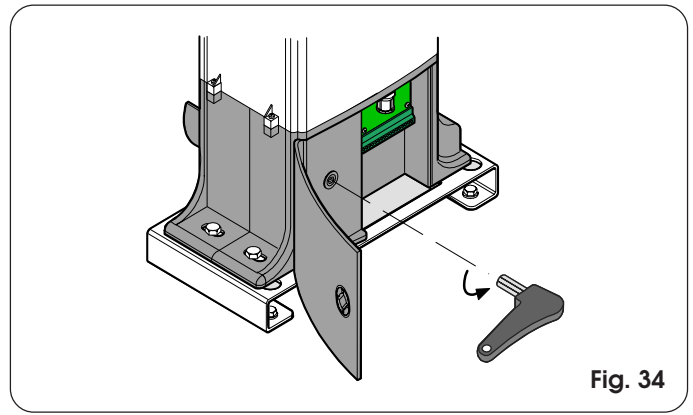
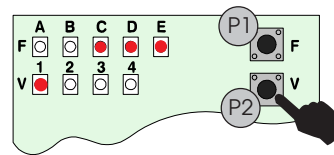

Fig. 34

**8.4 Status of inputs**

The board has a function for checking the status of inputs on the terminal board. In all LEDs OFF status (LEDs both with letters and numbers), press the P2 push-button.



When the LEDs light up, this indicates the inputs status as shown in Tab. 5.

Tab. 5 - Description of inputs status LEDs

LED	Lighted (closed contact)	Off (open contact)
A = Open A	Command active	<b>Command inactive</b>
B = Open B	Command active	<b>Command inactive</b>
C = Stop	<b>Command inactive</b>	Command active
D = Fsw op	<b>Safety devices disengaged</b>	Safety devices engaged
E = Fsw cl	<b>Safety devices disengaged</b>	Safety devices engaged
1 = Sensor	<b>Sensor disengaged</b>	Sensor engaged

**Notes:**

- The status of LEDs with the gate closed at rest is shown in **bold**.
- In the inputs status function, push-button P1 commands an OPEN A.

When checks have finished, once again press push-button P2 to exit the inputs status function.

### 8.5 Programming

These are the basic settings of the board:

Function logic:	<b>A4</b>
Pause times:	<b>B1</b>
Partial opening width:	<b>C2</b>
Static force:	<b>D3</b>
Speed:	<b>E3</b>

If you wish to execute customised programming (see par. from 8.5.1 to 8.5.5) and time-learning (see par.8.5.6) follow the steps in the next pages.

#### 8.5.3 Partial Opening Width

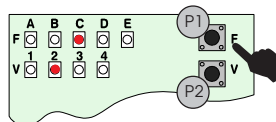

Press push-button P1 again and LED C will light together with LED 2.

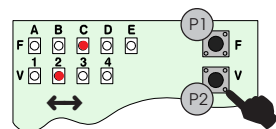

Press push-button P2, for a choice of 4 different partial openings.

- C1 90 cm
- C2 120 cm (default)
- C3 150 cm
- C4 180 cm

#### 8.5.1 Function Logic

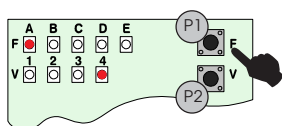

In all LEDs OFF status, press push-button P1. Led A will light up together with LED 4.

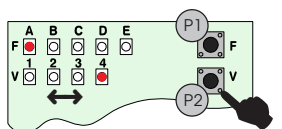

Press push-button P2, for a choice of 4 different function logics.

- A1 automatic
- A2 safety
- A3 Step-by-step automatic
- A4 Step-by-step semi-automatic (default)

#### 8.5.4 Static Force

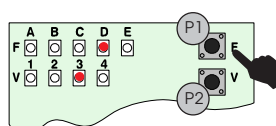

Press push-button P1 again and LED D will light together with LED 3.

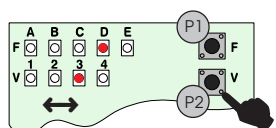

Press push-button P2, for a choice of 4 different static forces.

- D1 low
- D2 medium low
- D3 medium high (default)
- D4 high

#### 8.5.2 Pause Times

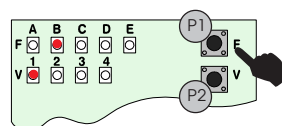

Press push-button P1 again and LED B will light together with LED 1.

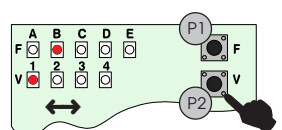

Press push-button P2, for a choice of 4 different pausetimes.

- B1 5 seconds (default)
- B2 10 seconds
- B3 20 seconds
- B4 30 seconds

#### 8.5.5 Speed

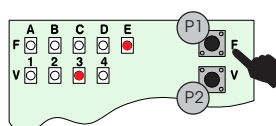

Press push-button P1 again and LED E will light together with LED 3.

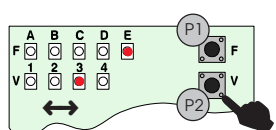

Press push-button P2, for a choice of 4 different speeds

- E1 low
- E2 medium low
- E3 medium high (default)
- E4 high

**8.5.6 Simple learning**

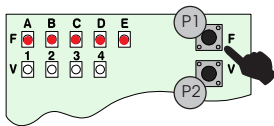

If you press push-button P1 again, all 5 LEDs from A to E will light.  
(Make sure that the gate is closed and operator locked)

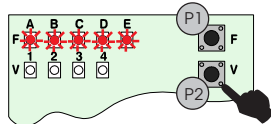

If you press push-button P2 for 1 second, the gate will start moving until the opening travel limit magnet engages the sensor on the operator. The 5 LEDs flash during this stage.  
After learning has been completed, the 5 LEDs remain lighted steadily.

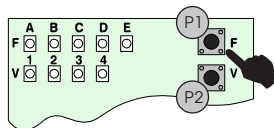

Press push-button P1 again to exit (all LEDs OFF). Give an OPEN A pulse with the radio control or the key push-button to close the gate.

**8.6 Status of indicator light**

If you wish to use a 12V-0.5W indicator light (terminal 9 - 11 of J1, see Fig. 20), the following table shows the statuses of the indicator light according to gate position.

**Tab. 6** - Statuses of indicator light

Indicator-light status	Gate status
Light Off	Closed
Lighted	Open - Open in pause
Flashing	Closing
Lighted	Opening
Lighted	Locked

**8.7 Testing the automated system**

After programming, run an accurate functional check of the automated system and of all the accessories connected to it, especially the safety devices.

**9. MANUAL OPERATION**

If the gate has to be moved manually due to a malfunction of the automated system, use the release device as follows:

- Open the protective door with a coin.
- Take the supplied key located inside the door, fit it in the release system and turn it clockwise until it reaches the mechanical stop (fig. 35).
- Open or close the gate manually.

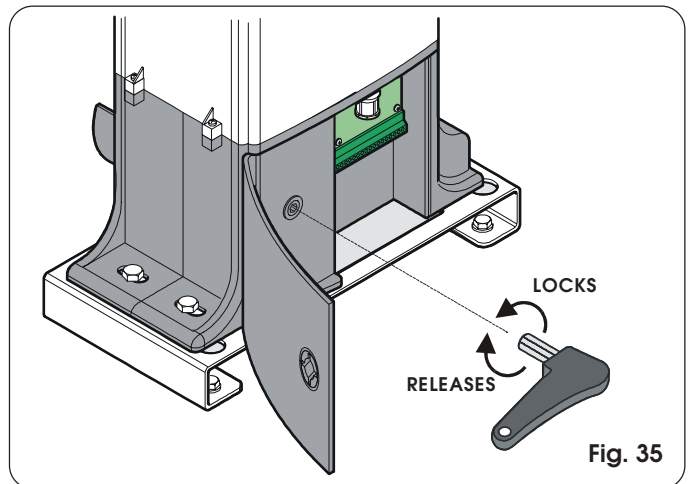

**10. RESTORING NORMAL OPERATION MODE**

Procedure to relock the gate:

- Manually take the gate back to its closed position.
- Turn the release key anti-clockwise until it reaches the mechanical stop (Fig. 35).
- Remove the release key and put it back in its place; close the protective door.
- Move the gate until the release meshes.

**11. MAINTENANCE**

Carry out the following jobs at least every 6 months:

- Check if the anti-crushing facility is correctly set.
- Check the efficiency of the release system.
- Check the efficiency of the safety devices and accessories.

**12. REPAIRS**

For any repairs, contact authorised Repair Centres.



Table 7/a

LOGIC "A"					
GATE STATUS	PULSES		STOP	OP/CL SAFETY DEVICE	
	OPEN-A	OPEN B		OPENING SAFETY DEVICES	CLOSING SAFETY DEVICES
CLOSED	Opens leaf/ves and re-closes after pause time		No effect (OPEN disabled)	No effect	No effect (OPEN disabled)
OPEN on PAUSE	Reloads pause time		No effect	Reloads pause time	
CLOSING	Re-opens the leaf/ves immediately		Stops operation	Immediately reverses to open	Locks and, on release, reverses at opening
OPENING	No effect		Immediately reverses to close	No effect	Locks and, on release, continues opening
LOCKED	Closes the leaf/ves		No effect	No effect (OPEN disabled)	

Table 7/b

LOGIC "S"					
GATE STATUS	PULSES		STOP	OP/CL SAFETY DEVICE	
	OPEN-A	OPEN B		OPENING SAFETY DEVICES	CLOSING SAFETY DEVICES
CLOSED	Opens leaf/ves and re-closes after pause time		No effect (OPEN disabled)	No effect	No effect (OPEN disabled)
OPEN on PAUSE	Re-closes the leaf/ves immediately		No effect	Closes after 5" (OPEN disabled) on release	
CLOSING	Re-opens the leaf/ves immediately		Stops operation	Immediately reverses to open	Locks and, on release, reverses at opening
OPENING	Re-closes the leaf/ves immediately		Immediately reverses to close	No effect	Locks and, on release, continues opening
LOCKED	Closes the leaf/ves		No effect	No effect (OPEN disabled)	

Table 7/c

LOGIC "AP"					
GATE STATUS	PULSES		STOP	OP/CL SAFETY DEVICE	
	OPEN-A	OPEN B		OPENING SAFETY DEVICES	CLOSING SAFETY DEVICES
CLOSED	Opens leaf/ves and re-closes after pause time		No effect (OPEN disabled)	No effect	No effect (OPEN disabled)
OPEN on PAUSE	Stops operation		No effect	Reloads pause time	
CLOSING	Re-opens the leaf/ves immediately		Stops operation	Immediately reverses to open	Locks and, on release, reverses at opening
OPENING	Stops operation		Immediately reverses to close	No effect	Locks and, on release, continues opening
LOCKED	Closes the leaf/ves		No effect	No effect (OPEN disabled)	

Table 7/d

LOGIC "EP"					
GATE STATUS	PULSES		STOP	OP/CL SAFETY DEVICE	
	OPEN-A	OPEN B		OPENING SAFETY DEVICES	CLOSING SAFETY DEVICES
CLOSED	Opens leaf/ves		No effect (OPEN disabled)	No effect	No effect (OPEN disabled)
OPEN	Re-closes the leaf/ves immediately		No effect	No effect (OPEN disabled)	
CLOSING	Stops operation		Stops operation	Immediately reverses to open	Locks and, on release, reverses at opening
OPENING	Stops operation		Immediately reverses to close	No effect	Locks and, on release, continues opening
LOCKED	After OPEN: Restarts moving in reverse direction After STOP: Re-closes the leaf/ves immediately		No effect (OPEN disabled) (if it must open, it disables OPEN)	No effect (OPEN disabled)	

**TROUBLESHOOTING**

Fault	Possible causes	Solution
Board LED P OFF	No mains power supplied for more than 5 minutes with battery charged	Just give an OPEN pulse to move the gate.
	No mains power supplied with battery discharged	The gate will stay locked until mains power returns and the battery is sufficiently recharged.
Automated system shut down. It does not move by any command (radio control or key operated selector switch).	Discharged batteries	Check if LED P of the board is OFF or flashing rapidly. In the latter case, allow the batteries to recharge.
	STOP (3) and FSW (4 and 5) terminals not connected.	Check the wiring as shown in the instructions and also check if LEDs C, D and E light correctly on the inputs status.
	Board fuse failed.	Check the fuse (F20A) and, if necessary, replace it.
Automated system shut down. Moves only by key-operated command.	No mains power supplied for more than 24 hours.	The radio receiver is re-activated when mains power returns or by giving a pulse with the key-operated selector switch; in this case, if mains power does not return within the next 24 hours, the receiver is once again powered down.
	Faulty radio control	Using another radio control, check if the system is operating correctly and, if necessary, replace the faulty radio control.
	Faulty receiver board	If the automated system is still shut down even after checking that radio control was not faulty, replace the receiver card.
Automated system shut down. The motor runs, but the gate does not move.	The motor has reached the travel limit mechanical stop.	Arrange the travel limit magnets as per instructions.
During movement, the automated system reverses motion for no reason.	Force too low (meeting an imaginary obstacle)	Check if there are any obstacles on the route of the gate, such as stones or uneven asphalt, and increase the static force of the motor.
The automated system performs the entire opening/closing travel in deceleration. or it stops on the travel limit device without performing deceleration.	Learning not executed correctly.	Execute learning as per instructions.
	The position of the travel limit magnet is not correct.	Check position of travel limit devices as per instructions and execute learning again
The gate reaches the mechanical stop at full speed.	The position of the travel limit magnet is not correct.	Check position of travel limit devices as per instructions and execute learning again

## User's guide

# DOMOGLIDE - B AUTOMATED SYSTEM

**Read the instructions carefully before using the product and store them for future use**

### GENERAL SAFETY REGULATIONS

If correctly installed and used, the DOMOGLIDE-B automated system ensures a high degree of safety.

Some simple rules on behaviour can prevent accidental trouble:

- Do not pass through the gate when it is moving. Wait for the gate to open fully before passing through it.
- Do not, on any account, stand in the gate's movement range.
- Do not stand near the automated system or allow children, persons or things to stand or lie there, especially while it is in use.
- Keep remote controls or other pulse generators away from children, to prevent the automated system from being activated involuntarily.
- Do not allow children to play with the automated system.
- Do not willingly obstruct gate movement.
- Prevent any branches or shrubs from interfering with gate movement.
- Keep indicator-lights efficient and easy to see.
- Do not attempt to activate the gate by hand unless you have released it.
- In the event of malfunctions, release the gearmotor to allow access and wait for qualified technical personnel to do the necessary work.
- Before using the manual release, disconnect the batteries.
- Do not in any way modify the components of the automated system.
- Do not attempt any kind of repair or direct action whatever and contact qualified personnel only.
- At least every six months: arrange a check of the automated system, safety devices and accessories.

### DESCRIPTION

These instructions apply to the following model:

#### FAAC DOMOGLIDE-B

The FAAC DOMOGLIDE-B automated system for residential sliding gates consists of a non-reversing electro-mechanical operator, powered on 12 Vdc, coupled to a control board with a work battery (not a back-up battery), ensuring operation even in the event of a mains power cut.

The non-reversing system guarantees the gate will automatically lock when the motor is not operating. A release system enables the gate to be moved by hand in case of malfunction.

The gearmotor is controlled by an electronic control unit housed inside the gearmotor where it is adequately protected against atmospheric agents.

The gates is normally in its closed position.

When the electronic control unit receives an opening command via the radio control or any other pulse generator, it activates the gearmotor to move the gate until it reaches the opening position to allow access.

If automatic mode was set, the leaves closes automatically after the selected pause time has elapsed.

If the semi-automatic mode was set, a second pulse must be sent to close the gate again.

A stop pulse (if supplied) always stops movement.

For details on the behaviour of the automated system in different function logics, consult the installation Technician.

Automated systems include safety devices that prevent the gate from moving when there is an obstacle in the area they protect.

The DOMOGLIDE-B automated system is provided with an adjustable anti-crushing device which reverses gate movement in case of contact with an obstacle.

The warning-light indicates that the gate is currently moving.

### MANUAL OPERATION

If the gate has to be moved manually due to a fault of the automated system, use the release device as follows:

- Open the protective door with a coin.
- Take the supplied key located inside the door, fit it in the release system and turn it clockwise until it reaches the mechanical stop (Fig. 1).
- Open or close the gate manually.

### RESTORING NORMAL OPERATION MODE

- Manually take the gate back to its closed position.
- Turn the release key anti-clockwise until it reaches the mechanical stop (Fig. 1).
- Remove the release key and put it back in its place; close the protective door.
- Move the gate until the release meshes.

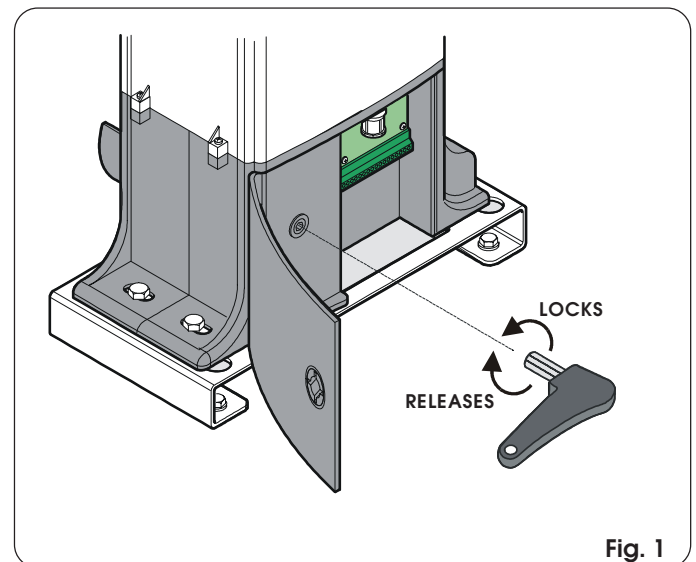

Fig. 1